

Eötvös Loránd University (ELTE)

Faculty of Natural Sciences

Institute of Physics

OPTICALLY DETECTED MAGNETIC RESONANCE SPECTROMETER IN A CONFOCAL
MICROSCOPE IN THE STUDY OF SOLID-STATE QUANTUM BITS

3rd semester research report

Doctoral School of Physics - Eötvös Loránd University (ELTE)

Nain Mukesh (mukesh.nain @wigner.mta.hu)

Wigner Research Centre for Physics

Supervisor: Adam Gali

Wigner Research Centre for Physics

Consultant: ELTE TTK Department of Atomic Physics

2020.01.26.

Introduction:

An optically detected magnetic resonance (ODMR) spectrometer in a confocal microscope arrangement which is deployed for coherent manipulation of electronic and nuclear spin states of individual room-temperature solid-state quantum bits, such as nitrogen-vacancy center in diamond by using illumination and microwave impulses. A nitrogen-vacancy center (N-V center) is one of numerous point defects in diamond. Its most explored and useful property is photoluminescence, which can be easily detected from an individual N-V center, especially those in the negative charge state (N-V⁻). Electron spins at N-V centers, localized at atomic scales, can be manipulated at room temperature by applying a magnetic field, electric field, microwave radiation or light, or a combination, resulting in sharp resonances in the intensity and wavelength of the photoluminescence. These resonances can be explained in terms of electron spin related phenomena such as quantum entanglement, spin-orbit interaction and Rabi oscillations, and analyzed using advanced quantum optics theory. An individual N-V center can be viewed as a basic unit of a quantum computer, and it has potential applications in novel, more efficient fields of electronics and computational science including quantum cryptography, spintronic and masers.

N-V⁻ centers emit bright red light which can be conveniently excited by visible light sources, such as argon or krypton lasers, frequency doubled Nd:YAG lasers, dye lasers, or He-Ne lasers. Excitation can also be achieved at energies below that of zero phonon emission. Laser illumination, however, also converts some N-V⁻ into N-V⁰ centers. Emission is very quick (relaxation time ~10 ns). At room temperature, no sharp peaks are observed because of the thermal broadening. However, cooling the N-V⁻ centers with liquid nitrogen or liquid helium dramatically narrows the lines down to a width of a few megahertz.

Tasks during the research:

1. Finding several types of defects in Non-diamonds for example Nitrogen Vacancy, SiC and Ge vacancy defects etc. (lit review)
2. Characteristics of defects which can be used in real life for instance Telecom, Quantum Computing as well as in medication.
3. Build a set up for optically detected magnetic resonance for Nano diamonds and SiC or to make Nano environment to accomplish the desired goal experimentally.
4. Synthesis in new experimental environment.
5. How we can use the results in the applications.
6. Provide the feedback and conclusion for new developments ideas for future references.

Description of research work carried out in current semester: I participated in two courses one is Transmission electron Microscopy(8 credits) and another was Physical materials Sciences(8credits) .

Main tasks performed for the project during the semester along with the lit knowledge was:

1. synthesis of SiC with Si Vacancy with different methods and different compositions Al materials for example the standard concentrations of preparing SiC are Si = 2.8g , C = 1.2g , PTFE 0.6g ,EtOH =20g with varying Al compositions and different time intervals.
2. How to use different instruments for carrying out the synthesis of SiC with Si Vacancy For instance Powder methodology for refining the grain size up to 2-3mm with SPD process.
3. Observation of Raman spectra with Raman spectrometer under the excitation of different laser power(green 531nm, red laser 634 and 741) with different excitation intensities i.e. 1%,5%,10%,50%and 100%, Usually at 100% full power the detector saturates and gives fault data.
4. Observation of Raman peaks with different composition of partially and fully prepared SiC of varying time intervals for polytypes (1-100nm) followed with other materials Si (twin peaks), C and SiC.
5. PL spectra with different laser power excitation.
6. X-ray spectrum of SiC.
7. Compare the result with lit research
8. Building Optical set up for ODMR signal from SiC.

The experiment for the SiC with Si Vacancy in 3C4H SiC was successfully done. It was measured by X-ray diffraction technique. The next task is to produce 6H SiC during the 4th semester and the Promising result will be published as well for both 3C 4H and 6H SiC.

Nitrogen-vacancy centers are typically produced from single substitutional nitrogen centers (called C or P1 centers in diamond literature) by irradiation followed by annealing at temperatures above 700 °C. A wide range of high-energy particles are suitable for such irradiation, including electrons, protons, neutrons, ions, and gamma photons. Irradiation produces lattice vacancies, which are a part of N-V centers. Those vacancies are immobile at room temperature, and annealing is required to move them. Single substitutional nitrogen produces strain in the diamond lattice. It therefore efficiently captures moving vacancies, producing the N-V centers.

An important property of the luminescence from individual N-V– centers is its high temporal stability. Whereas many single-molecular emitters bleach after emission of 106–108 photons, no bleaching is observed for the N-V centers at room temperature.

Because of these properties, the ideal technique to address the N-V centers is confocal microscopy, both at room temperature and at low temperature. In particular, low temperature operation is required to specifically address only the zero-phonon line (ZPL).

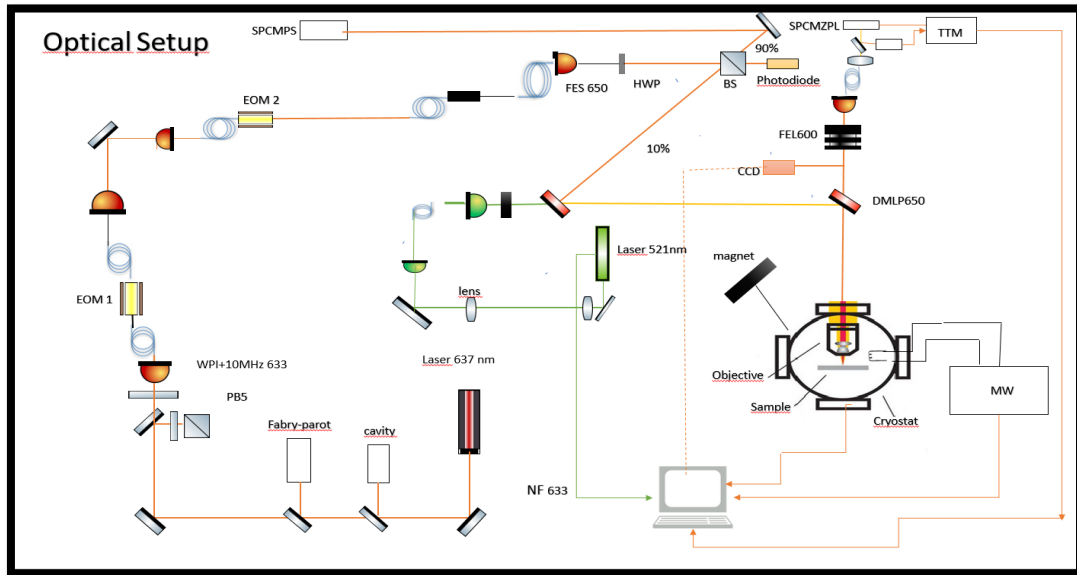

Fig 1: optical set up plan for ODMR measurement

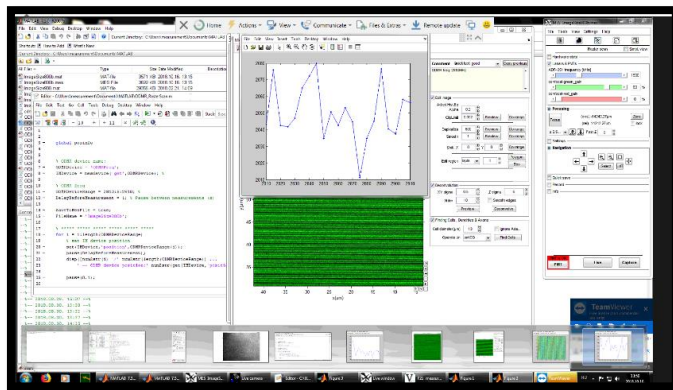

Fig 2: Extracted ODMR signal from confocal microscope



Fig 3:(a,b)Processing of bulk ultrafine-grained metals and alloys by powder metallurgy with Hot pressing technique.

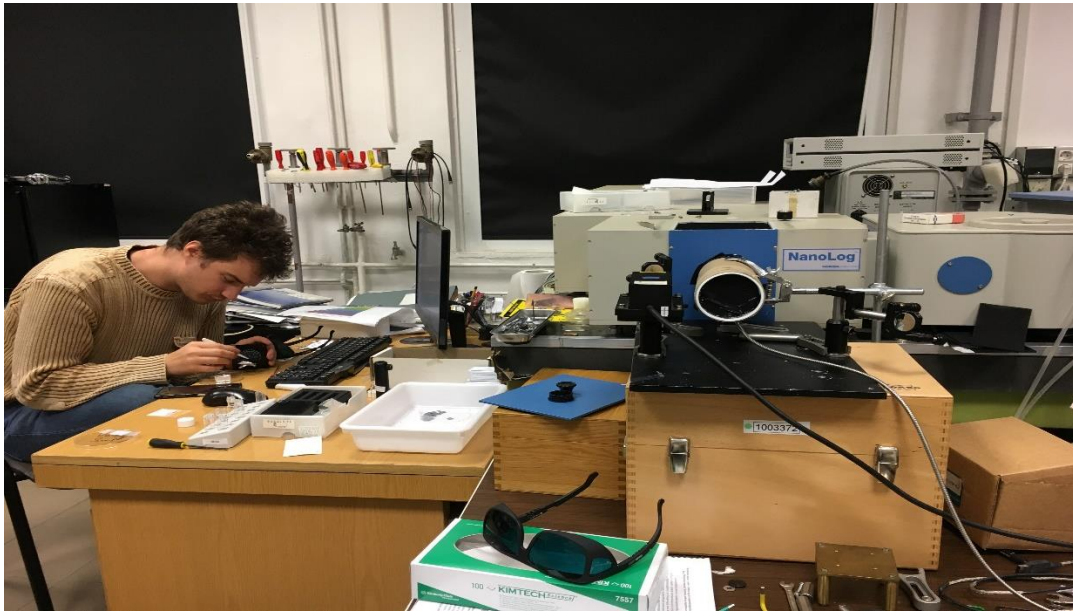

Fig 4:left:optical arrangement for Si vacancy signal at cryogenic temp

Normal SiC Vs time and AlSiC polytypes Vs Time

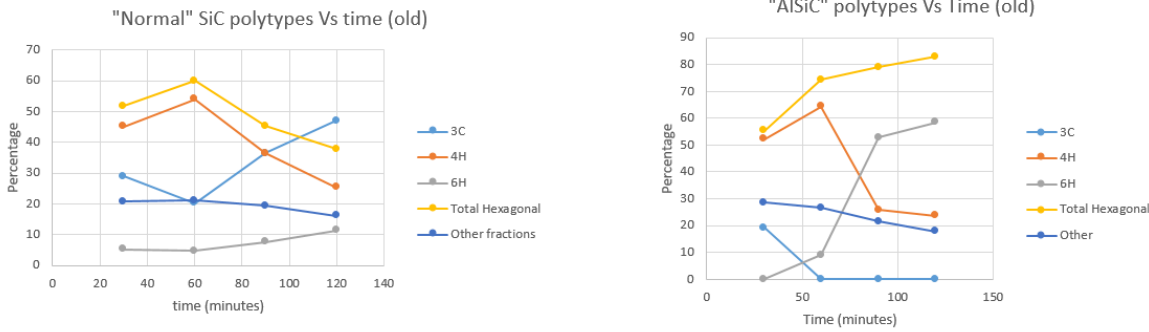

Fig 5: Demonstration feedback by origin software of prepared Normal SiC Vs time and Sic Polytype Vs time sample with Al content in it.

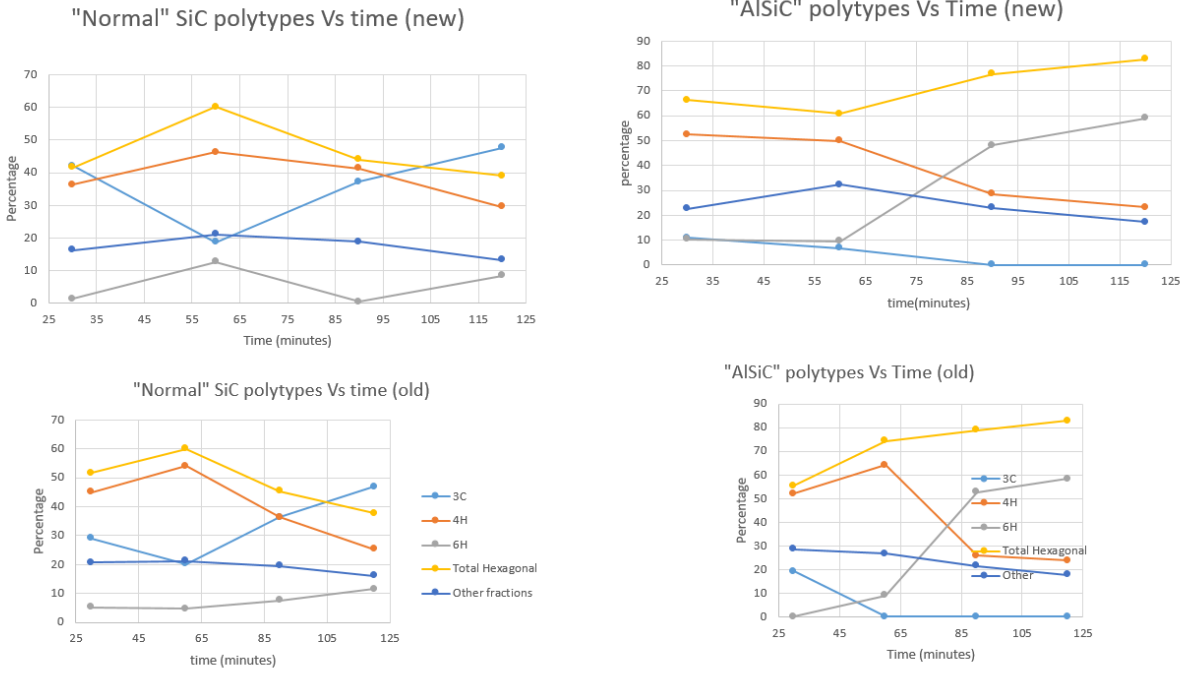

Fig 6: Demonstration feedback in MS office software of prepared comparision of normal SiC Vs time and Sic Polytype Vs time sample with Al content in it of new and old samples

Softwares: MES (measurement experiment science) software has been used to extract the ODMR signal with the compatible Matlab Script. The system software has shown remarkable results from surface scanning to point scanning of nano diamond and SiC.

Origin is a proprietary computer program for interactive scientific graphing and data analysis. It is produced by OriginLab Corporation, and runs on Microsoft Windows. It has inspired several platform-independent open-source clones like SciDAVis. Graphing support in Origin includes various 2D/3D plot types.

Data analyses in Origin include statistics, signal processing, curve fitting and peak analysis. Origin's curve fitting is performed by a nonlinear least squares fitter which is based on the Levenberg–Marquardt algorithm. Origin imports data files in various formats such as ASCII text, Excel, NI TDM, DIADem, NetCDF, SPC, etc. It also exports the graph to various image file formats such as JPEG, GIF, EPS, TIFF, etc. There is also a built-in query tool for accessing database data via ADO.

Plan for the next semester:

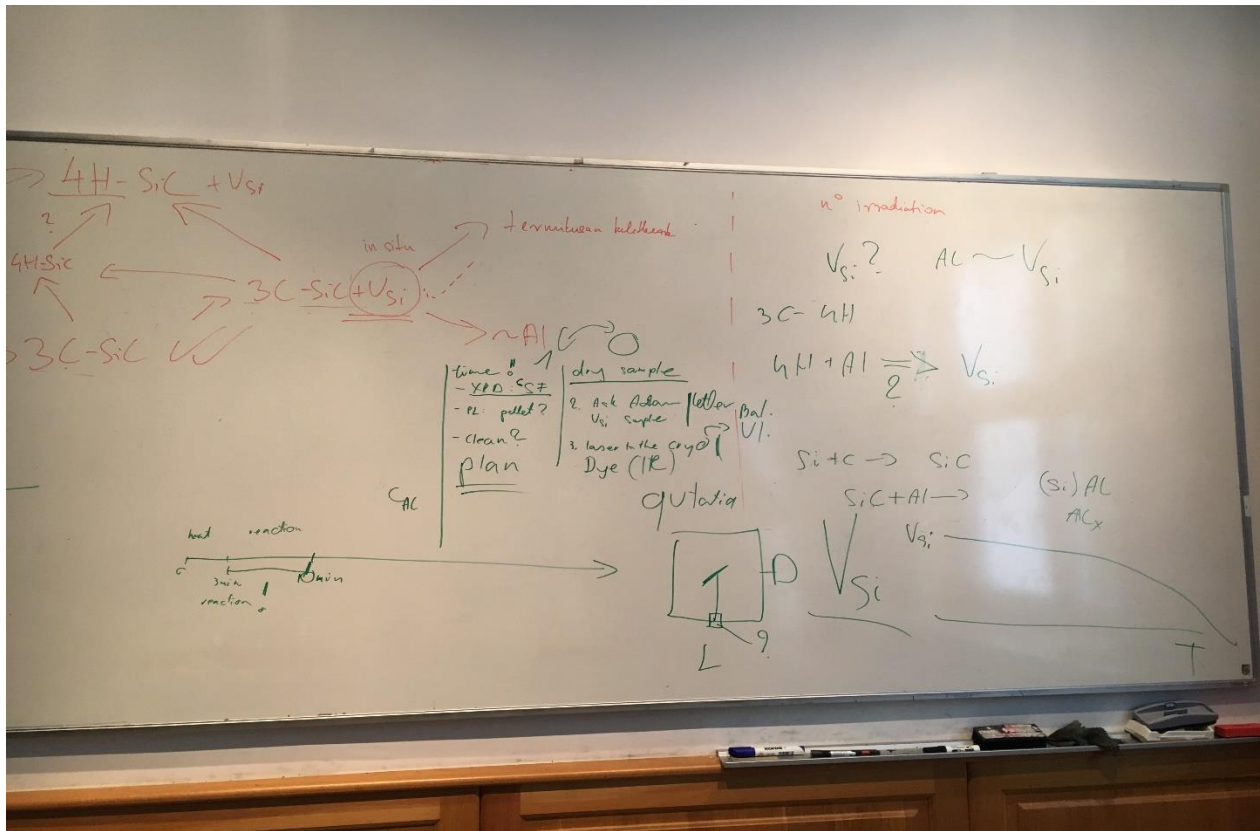

Fig 6: Demonstration for the next semester plan

Also I would learn how to use Easy spin program software for Analysis of Spin and otherAnalytics based on Matlab.